



Adventurer[®]

Analytical and Precision Balances

TECHNICAL ADVANTAGES

Authorised OHAUS Australia Dealer
www.techadv.com.au
sales@techadv.com.au



The Most Complete Balance in its Class!

Striking the ideal balance between inventive features and functional, uncomplicated weighing capabilities, the OHAUS Adventurer incorporates all of the applications necessary for routine weighing and measurement activities. With a color touchscreen, GLP/GMP compliance capabilities, two USB ports, ingenious draftshield, and much more, Adventurer is the most complete balance in its class.

Standard Features Include:

- **Stability, Accuracy, and Fast Operation Ensure Optimal Weighing Results** — This trio of characteristics ensures the most important aspects of routine laboratory weighing are covered: accurate results you can count on extremely quickly.
- **Color Touchscreen & Connectivity Options Power a Modern Weighing Experience** — The wide viewing angle color touchscreen provides quick access to all of Adventurer's applications, while dual USB ports with GLP/GMP tracking capabilities assist in the monitoring and reporting of data.
- **Space-saving Draftshield Improves User Experience and Accessibility** — The two piece, top-mounted draftshield doors open wide on both sides, providing ample room for sample placement, and also reduce the footprint of the draftshield in the rear of the balance when open.

Adventurer[®] Analytical and Precision Balances

Stability, Accuracy, and Fast Operation Ensure Optimal Weighing Results in Routine Weighing Tasks

Weighing Performance

- Delivers stable and reliable weighing results for routine weighing tasks

Stabilization Time

- Adventurer's fast stabilization time improves productivity in the laboratory

Calibration

- **AutoCal™**
 - Select models feature OHAUS' automatic internal calibration system that performs routine maintenance by calibrating the balance daily.
- **External Calibration**
 - Traditional calibration in which the operator manually calibrates the balance with their choice of calibration weight value to ensure accuracy available on every model.



Color Touchscreen Offers Easy and Fast Operation of Adventurer's Applications

- Operate and access Adventurer's nine application modes and abundant features that eliminate the need to do several manual calculations through the modern color touchscreen
- Operators can wear laboratory gloves while utilizing the touchscreen, eliminating the inconvenience and hazards associated with constantly putting on and removing gloves
- In addition to the touchscreen, Adventurer also has six mechanical keys that provide tactile feedback and allow the operator to perform repetitive operations such as tare, zero, calibration, and print



Application Modes



Weighing

Determine the weight of items in the selected unit of measure.



Parts Counting

Count samples of uniform weight.



Percent Weighing

Measure the weight of a sample displayed as a percentage of a pre-established Reference Weight.



Dynamic Weighing

Weigh an unstable load. Scale takes an average of weights over a period of time.



Density Determination

Determine density of solids or liquid. With the weigh below hook, it's possible to perform specific gravity tests for objects that cannot be easily placed on the weighing pan.



Check Weighing

Compare the weight of a sample against target limits.



Display Hold

Manually holds the last stable weight or highest weighing value on the display.



Totalization

Measure cumulative weight of multiple items. Cumulative total may exceed balance capacity.



Formulation

For compounding and recipe making. The number of components can range from 2 to 50.

Equipped with the Connectivity and Functional Features Required in Laboratories

Dual USB Ports

- A front USB host port is easily accessible and makes it simple to load data from the balance on to a flash drive without having to reach around to the back or move the balance
- A second USB device is located at the rear of the balance that can be used to connect the balance to a PC
- The connectivity options help meet traceability requirements in traditional installations



Real Time Clock with GLP/GMP Data

- A real-time clock function keeps accurate time even during power loss and the GLP data capability has the ability to record Sample name, Project names and Balance ID's to help meet traceability and compliance requirements

Balance Profiles

- The cloning feature allows you to save user and application settings to a USB flash drive which can be easily used to configure additional Adventurer balances

Below Minimum Sample Weight Indication

- When using the minimum weight feature, the display clearly indicates that your current sample weight is below your defined minimum limit. Simply increase your sample weight to assure that your results are up to your standards

Space-saving Draftshield Designed to Improve User Experience and Accessibility

- Draftshield doors are constructed of two glass panels, reducing the space required on the lab bench when the doors are open
- Wide door entry provides unobstructed access and allows larger weighing vessels to be easily placed on the pan, reducing the chance of accidental spillage
- Easy to keep clean in order to ensure a safe workspace by minimizing contamination



Outline Dimensions

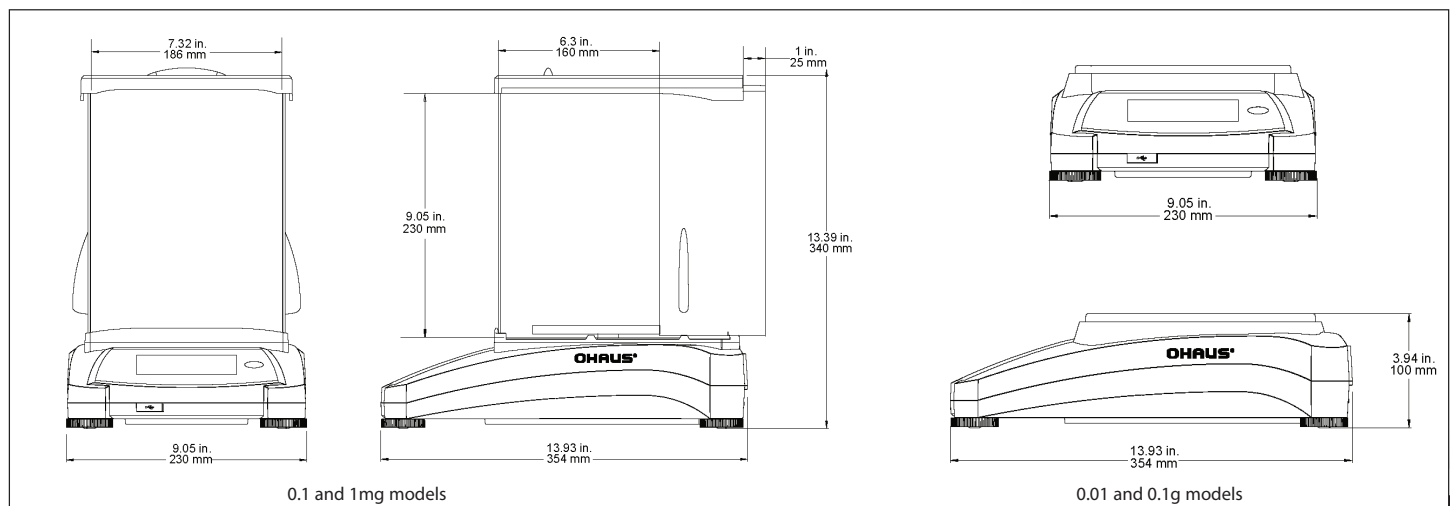

Adventurer[®] Analytical and Precision Balances

Model	AX124	AX224	AX324	AX223	AX423	AX523	AX622	AX1502	AX2202	AX4202	AX5202	AX4201	AX8201
External Calibration	AX124/E	AX224/E	—	AX223/E	AX423/E	AX523/E	AX622/E	AX1502/E	AX2202/E	AX4202/E	—	AX4201/E	AX8201/E
Approved Models	AX124M	AX224M	AX324M	AX223M	AX423M	AX523M	—	AX1502M	AX2202M	AX4202M	AX5202M	—	AX8201M
Capacity (g)	120	220	320	220	420	520	620	1,520	2,200	4,200	5,200	4,200	8,200
Readability d (g)	0.0001			0.001			0.01			0.1			0.1
Verification Interval* e (g)	0.001			0.01			—	0.1			—	1	
Class*	I			II			—	II			—	II	
Repeatability std (g)	±0.0001			±0.001			±0.01			±0.1			
Linearity (g)	±0.0002			±0.002			±0.02			±0.2			
Stabilization Time (sec)	≤3			≤2			≤1.5			≤1.5			
Sensitivity Drift (ppm/°C)	1.5			3			3			1.9	9		
Typical Operating Range (g) (u=0.10%, k=2)	0.20g - 120g	0.20g - 220g	0.20g - 320g	2.0g - 220g	2.0g - 420g	2.0g - 520g	20.0g - 620g	20.0g - 1,520g	20.0g - 2,200g	20.0g - 4,200g	20.0g - 5,200g	200.0g - 4,200g	200.0g - 8,200g
Optimal Operating Range (g) (u=0.10%, k=2)	0.082g - 120g	0.082g - 220g	0.082g - 320g	0.82g - 220g	0.82g - 420g	0.82g - 520g	8.2g - 620g	8.2g - 1,520g	8.2g - 2,200g	8.2g - 4,200g	8.2g - 5,200g	82g - 4,200g	82g - 8,200g
Weighing Units	gram, milligram, mesgal, momme, Newton, ounce, pennyweight, Baht, carat, grain, pound, Tael (Hong Kong), Tael, (Singapore), Tael (Taiwan), tical, tola, troy ounce, custom (1)												
Weighing Units, Approved Models	mg, g, ct						—	g, kg, ct			—	g, kg, ct	
Weighing Applications	Weighing, Parts Counting, Percent Weighing, Check Weighing, Dynamic Weighing, Formulation, Density Determination, Totalization, Display Hold												
Pan Size	Ø 90 mm / 3.5 in			Ø 130 mm / 5.1 in			175 × 195 mm / 6.9 × 7.7 in						
Calibration	All models feature external calibration. Models feature AutoCal™ internal calibration, except for AX.../E models												
Tare Range	To capacity by subtraction												
Power Requirements	AC Adapter Input: 100-240 VAC 0.3A 50-60 Hz AC Adapter Output: 12 VDC 0.84A												
Display Type	Full-Color Touchscreen WQVGA Graphic LCD												
Display Size	109 mm / 4.3 in (diagonal)												
Base Housing (WxHxD)	354 × 340 × 230 mm / 13.93 × 13.39 × 9.05 in						354 × 100 × 230 mm / 13.93 × 3.94 × 9.05 in						
Communication	RS232, USB Device, USB Host												
Temperature Range	10°C to 30°C / 50°F to 86°F												
Humidity Range	Maximum relative humidity 80 % for temperatures up to 30°C / 86°F												
Storage Conditions	-10°C / 14°F to 60°C / 140°F at 10% to 90% relative humidity, non-condensing												
Shipping Dimensions	507 × 387 × 531 mm / 20.0 × 15.4 × 20.9 in						557 × 392 × 301 mm / 22.0 × 15.5 × 11.9 in						
Net Weight	5.1 kg			5.8 kg			4.6 kg			3.8 kg			
Shipping Weight	7.8 kg			8.5 kg			6.5 kg			5.7 kg			

*Approved models only

Additional Features

RS232 interface, integral weigh below hook, full housing in-use cover, removable stainless steel pan, die-cast metal bottom housing, security bracket, illuminated up-front level indicator, four adjustable feet, software lockout menus, stability indicator, software overload/underload indicators, user selectable environmental settings, audible indicator, user selectable brightness settings, auto dim, touchscreen calibration, auto tare, user selectable operating language (nine)

Approvals

Metrology: OIML R76, EN 45501 (Class I, nmax 320000; Class II, nmax 52000)
Product Safety: EN 61010-1, IEC 61010-1
Electromagnetic Compatibility: IEC 61326-1, EN 61326-1 (emissions Class B, immunity Industrial requirements)

Accessories

SF40A Impact Printer	30045641
Auxiliary Display	80251396
Density Determination Kit	80253384
Cable, USB Interface (Type A to B)	83021085
Security Device (Laptop Lock)	80850043
RS232 Cable, PC 25 Pin	80500524
RS232 Cable, PC 9 Pin	80500525

OHAUS Europe GmbH

Im Langacher 44
8606 Greifensee
Switzerland

e-mail: ssc@ohaus.com
Tel: 0041 22 567 53 19
e-mail: tsc@ohaus.com
Tel: 0041 22 567 53 20

www.ohaus.com

With offices throughout Europe,
Asia, and Latin America

ISO 9001:2008

Registered Quality
Management System

