

# Table of Contents

<b>1. INTRODUCTION</b> .....	<b>2</b>
1.1. Approvals (for trade versions only) .....	2
1.2. Manuals .....	2
<b>2. SHIPPING CONTENTS</b> .....	<b>2</b>
<b>3. SPECIFICATIONS</b> .....	<b>3</b>
<b>4. WARNINGS</b> .....	<b>4</b>
4.1. General .....	4
4.2. Configuration Issues .....	4
<b>5. INSTALLATION</b> .....	<b>4</b>
5.1. Electrical Safety .....	5
5.2. Panel Mount Template .....	5
5.3. Special Function Key .....	5
5.4. opto-LINK.....	6
<b>6. CONNECTIONS</b> .....	<b>7</b>
6.1. Cable Connections .....	7
6.2. DC Power (DC PWR + , DC PWR –).....	7
6.3. Load Cell Connection .....	7
6.4. Auxiliary Connections .....	9
6.5. Connecting Shields.....	13
6.6. Regulatory Sealing Requirements .....	14
<b>7. INSTRUMENT SETUP</b> .....	<b>15</b>
7.1. Calibration Counter .....	15
7.2. opto-LINK.....	15
7.3. Access Full Setup .....	16
7.4. Access Safe Setup .....	16
7.5. Exit Full or Safe Setup .....	16
7.6. Settings .....	16
<b>8. ERROR MESSAGES</b> .....	<b>25</b>
8.1. Weighing Errors .....	25
8.2. Setup and Calibration Errors .....	26
8.3. Diagnostic Errors .....	28

## 1. Introduction

This manual contains information on the installation, calibration and setup of the instrument.

### 1.1. Approvals (for trade versions only)

- NSC approval (4000 divisions at 0.8 $\mu$ V/division).
- NMI approval (4000 divisions at 0.8 $\mu$ V/division).
- C-tick approved and CE approved.

### 1.2. Manuals

For more information on this instrument refer to the **Reference Manual, Quick Start Manual** or **Communications Manual**.

## 2. Shipping Contents

The following table identifies the items shipped with the indicator. Please check that your packing box contains the specified items.

Shipped Items	Other Items (Optional)
<ul style="list-style-type: none"><li>• Indicator</li><li>• Operator Manual</li><li>• Quick Start Manual</li><li>• Trade Label (plastic)</li><li>• Panel Mount Template</li><li>• Function Key Overlay Stickers</li></ul>	<ul style="list-style-type: none"><li>• opto-LINK Cable</li><li>• Power Supply</li><li>• Desk Mount with Battery Compartment</li><li>• U Bracket</li></ul>

## 3. Specifications

Performance		
Resolution	Up to 30,000 divisions, minimum of 0.25 $\mu$ V/division, 20 updates/second (Trade 4000 divisions at 0.8 $\mu$ V/division)	
Zero Cancellation	$\pm$ 2.0mV/V	
Span Adjustment	0.1mV/V to 3.0mV/V full scale	
Stability/Drift	Zero: < 0.1 $\mu$ V/ $^{\circ}$ C (+ 8ppm of deadload max) Span < 8 ppm/ $^{\circ}$ C, Linearity < 20ppm, Noise < 0.2 $\mu$ Vp-p	
Excitation	5 volts for up to 4 x 350 or 8 x 700 ohm load cells (4-wire or 6-wire plus shield) Maximum total load cell resistance: 1,000 ohms	
A/D Type	24bit Sigma Delta with 8,388,608 internal counts	
A/D Conversion Rate	20Hz with FIR filtering > 80dB	
Operating Environment	Temperature: -10 to +50 $^{\circ}$ C ambient Humidity: <90% non-condensing Storage: -20 to +50 $^{\circ}$ C ambient IP55 when panel mounted	
Case Materials	ABS, Silicon Rubber, Nylon, Acrylic (no halogen used)	
Packing Weights	Basic Indicator: 0.34kg	
Digital		
Display	LED Backlit LCD with six 20mm high digits with units and annunciators	
Setup and Calibration	Full digital with visual prompting in plain messages	
Digital Filter	Sliding window average from 0.1 to 4.0 seconds	
Zero Range	Adjustable from $\pm$ 2% to $\pm$ 20% of full capacity	
Power Input		
Standard Power Input	12 to 24VDC (2.5 VA max) - ON/OFF key with memory feature	
Variants	AC	AC Plug pack: 110/240VAC 50/60Hz in 12VDC 0.5A out
	Battery	4 x AA batteries (Alkaline or rechargeable NiMH, NiCad, etc.)
Features		
opto-LINK Data Coupling	Infra-red Connector for optional opto-LINK PC cable (to RS-232 PC port)	
Correction	Five point linearity correction	
Outputs	RS-232 automatic transmit, network or printer outputs. Transmission rate: 2400, 4800 or 9600 baud	
Assignable Function Key	Unit switching, counting, manual hold, peak hold, live weight and totalising	
Drive Outputs	2 isolated transistor drive outputs (300mA total at 50VDC)	
Battery Backed Clock Calendar	Battery life 10 years minimum	

## 4. Warnings

### 4.1. General

- Indicator not to be subject to shock, excessive vibration or extremes of temperature (before or after installation).
- Inputs are protected against electrical interference, but excessive levels of electro-magnetic radiation and RFI may affect the accuracy and stability.
- For full EMC or for RFI immunity, termination of cable shields and correct earthing of the instrument is essential.
- Indicator and load cell cable are sensitive to excessive electrical noise. Install well away from any power or switching circuits.

### 4.2. Configuration Issues

- Configuration and calibration can be performed from the front panel, using digital setup. When Full Setup is used, all menu items are accessible and care must be taken to ensure no accidental changes are made to calibration and trade settings.
- Enter a passcode to prevent unauthorised or accidental tampering. If the passcode is lost, the manufacturer should be contacted for further advice.

## 5. Installation

The following steps are required to set up the indicator.

- Inspect indicator to ensure good condition.
- Use connection diagrams to wire up load cell, power and auxiliary cables as required.
- Use the drill hole template provided for hole locations.
- Connect Power to indicator and press **<POWER>** key to turn the instrument On.
- Refer to the Instrument Setup section page 15 for information on configuring and calibrating the instrument.
- To turn instrument Off press and hold **<POWER>** key for three seconds (until display blanks).

## 5.1. Electrical Safety

- For your protection all mains electrical hardware must be rated for environmental conditions of use.
- Pluggable equipment must be installed near an easily accessible power socket outlet.
- To avoid the possibility of electric shock or damage to the instrument, always switch off or isolate the instrument from the power supply before maintenance is carried out.

## 5.2. Panel Mount Template

Use the panel mount template for drill hole locations. The template indicates positions for the two 4mm mounting screws through the panel. Also displayed on the template is the position of the rectangular hole that should be cut to allow for the connection of cables. The drilling template supplied with the indicator allows for front or rear machining of the panel.

## 5.3. Special Function Key

- The Special Function Key on the instrument ships as a blank key.
- If any of the special functions are to be used on the indicator it is important that the matching function key overlay sticker (supplied) is applied to the keypad.
- Ensure keypad is clean and dry before affixing sticker.

## 5.4. opto-LINK

The optional opto-LINK cable can be used to transfer setup and calibration information from a PC (eg. to be stored for later use and/or transferred to other instruments). It can also be used to download software upgrades to the instrument from a PC.



- Attach the opto-LINK cable to the PC using the DB9 connector.
- Attach the opto-LINK head to the left side of the instrument display using the permanent magnet located within the head of the opto-LINK.

**WARNING:** The opto-LINK head contains a strong magnet and care should be taken with its proximity to electronic media (eg. credit cards, floppy disks, etc.) and/or other electronic instrumentation.

### 5.4.1. opto-LINK Activation

A long press of the **<GROSS/NET>** key will toggle the opto-LINK infrared communications On/Off.

When the opto-LINK has been (enabled) the following will occur:

- The instrument briefly displays the prompt **opto-L**.
- The editing annunciators (ie. GRP, ITM, etc.) will flash for up to five minutes while the instrument searches for activity. During this period, the instrument also disables the RS-232 communications.
- **Activity Located:** If the instrument is **successful** in locating activity, the editing annunciators will continue to flash during the entire period of communications.
- **No Activity Located:** If the instrument **fails** to locate activity, the opto-LINK will be disabled and the editing annunciators will stop flashing. The instrument will also revert back to the normal RS-232 communications (ie. the SERIAL:TYPE setting will be re-activated).

## 6. Connections

### 6.1. Cable Connections

- All cable connections are made to the rear of the instrument using screwless terminals.
- Wires must be stripped of insulation by at least 10mm.
- To install, depress the orange lever beside the terminal required and push wire into the hole. Release the lever and pull gently on the wire to ensure it is securely trapped in the terminal.

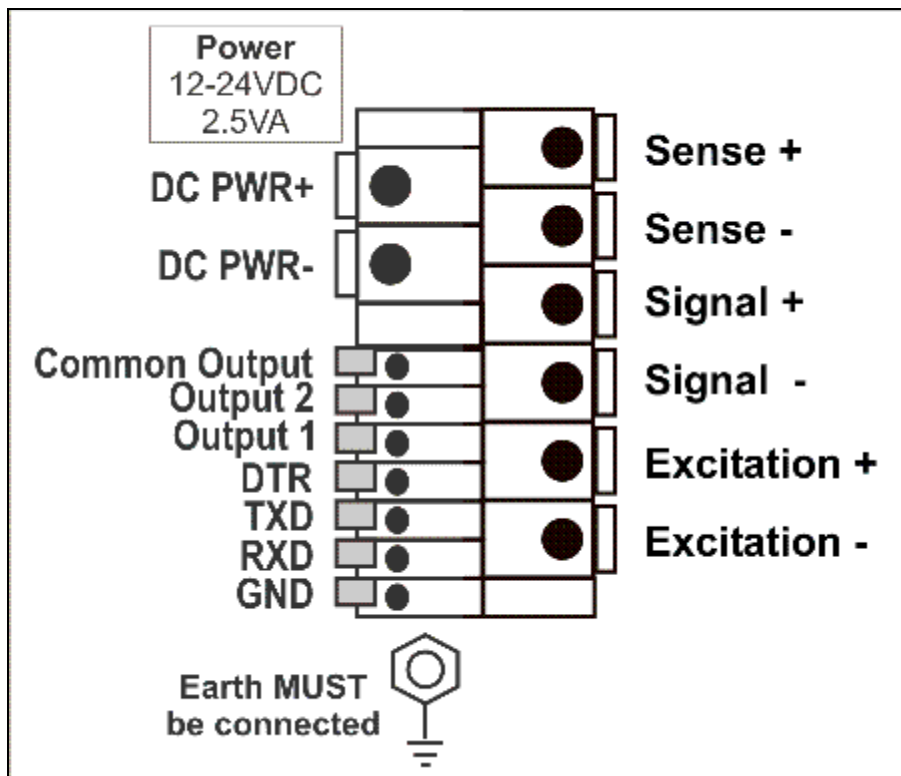

### 6.2. DC Power (DC PWR + , DC PWR –)

- The DC supply need not be regulated, provided that it is free of excessive electrical noise and sudden transients.
- The instrument can be operated from a high quality plug-pack as long as there is sufficient capacity to drive both it and the load cells.

### 6.3. Load Cell Connection

The instrument may be connected for either 4-wire or 6-wire operation. For more information, refer to **BUILD:CABLE** setting page 17.

### 6.3.1. 4-Wire Connection

The minimum connectivity requirements are the connection of four wires (ie. Excitation + and – along with Signal + and –).

The BUILD:CABLE option must be set to 4 to allow for 4-wire connection.

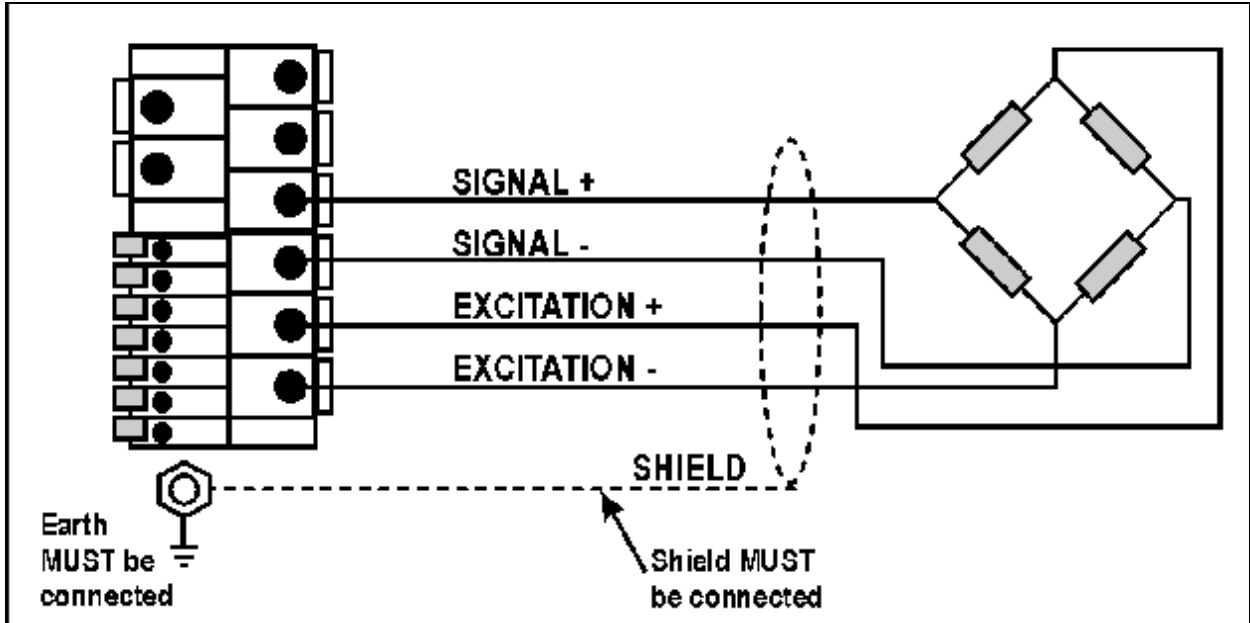

### 6.3.2. 6-Wire Connection

The excitation and signal lines are connected the same as for a 4-wire installation.

The BUILD:CABLE option must be set to 6 (the default) to allow for 6-wire connection.

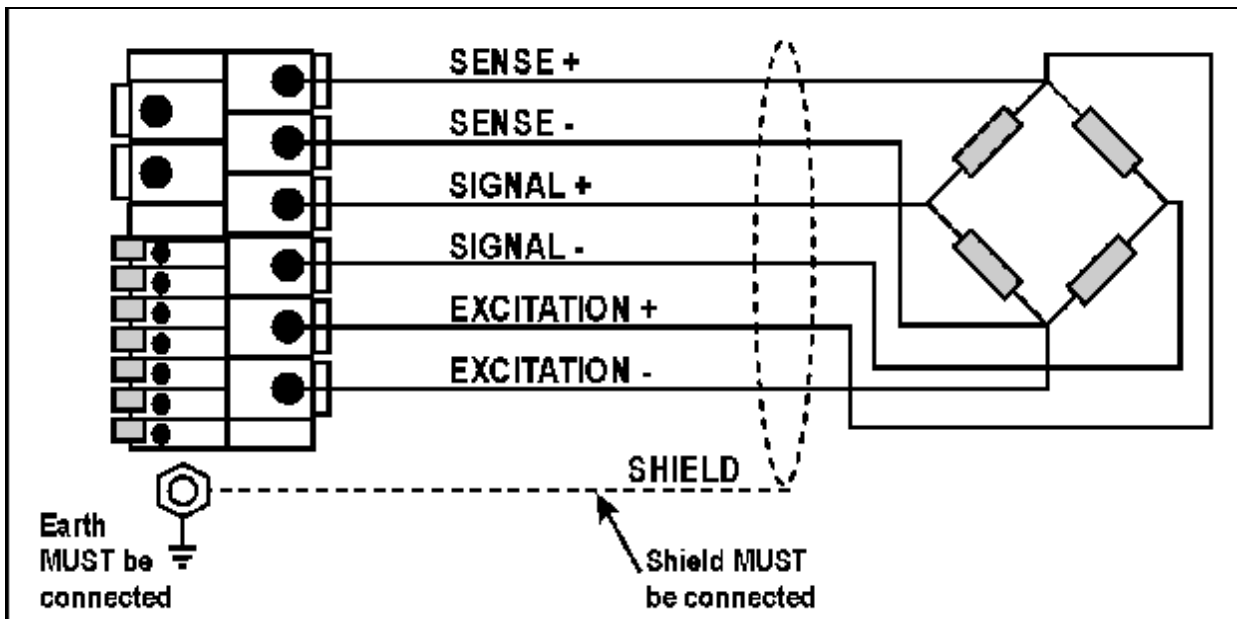

## 6.4. Auxiliary Connections

This section provides diagrams to illustrate the terminal connections.

### 6.4.1. Direct Personal Computer Link (RXD, TXD, GND) RS-232 - Instrument to PC using COM Port (DB9)

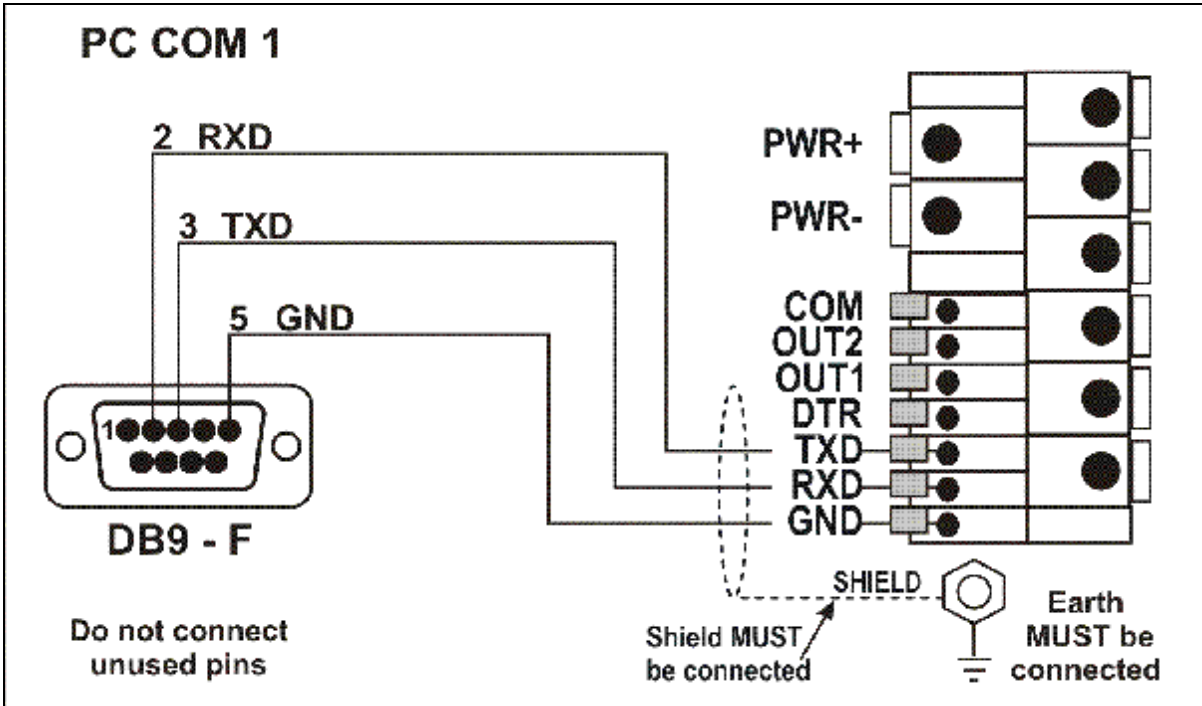

### RS-232 - Instrument to PC using COM Port (DB25)

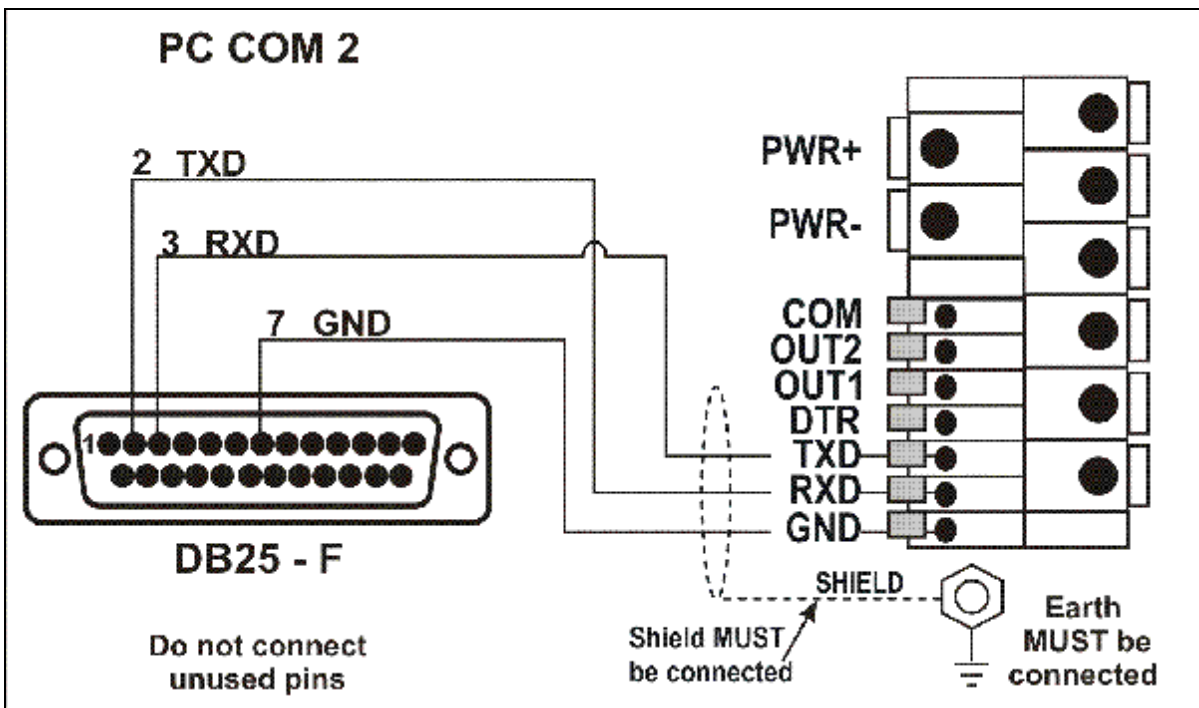

### 6.4.2. Printer Connections (RXD/TXD, GND and DTR) RS-232 – Instrument to Printer (DB25)

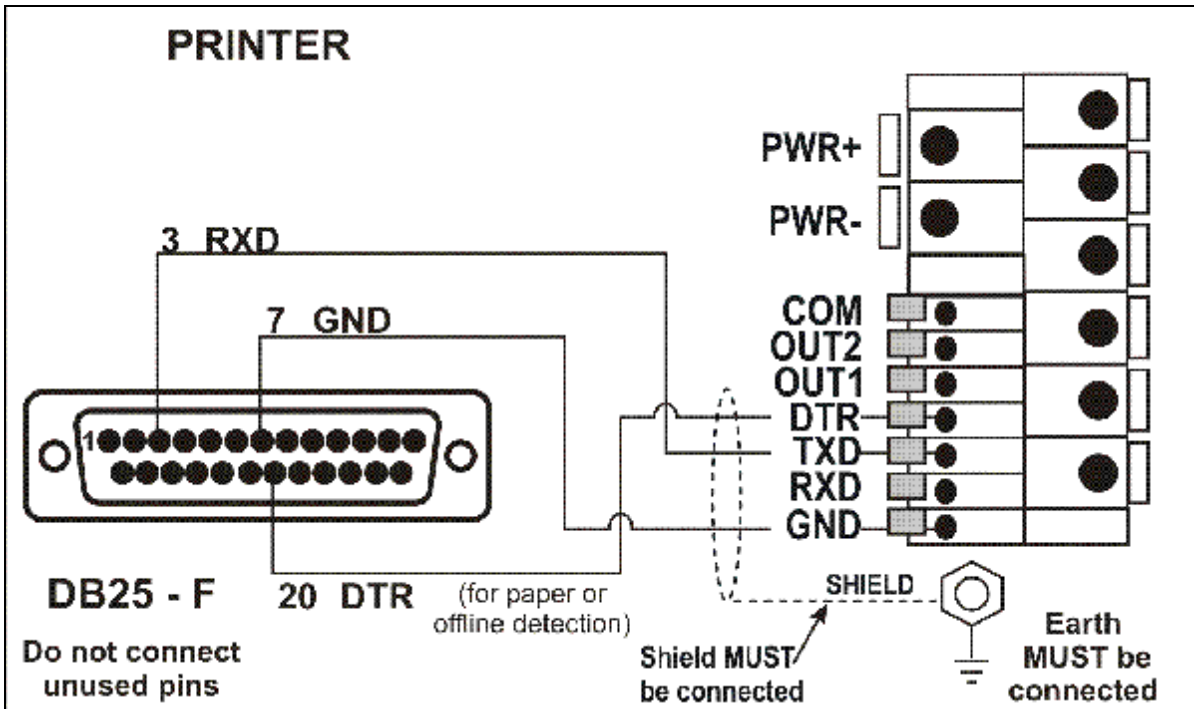

### 6.4.3. Remote Display (TXD, GND)

- Connect TXD to RXD and GND to GND on the remote display.

### 6.4.4. Remote Input

- The indicator requires a voltage free contact between TXD and RXD to enable the remote input (ie. SPEC:REM.FN).  
**Note:** The remote input will not function when in setup or when using the opto-LINK.

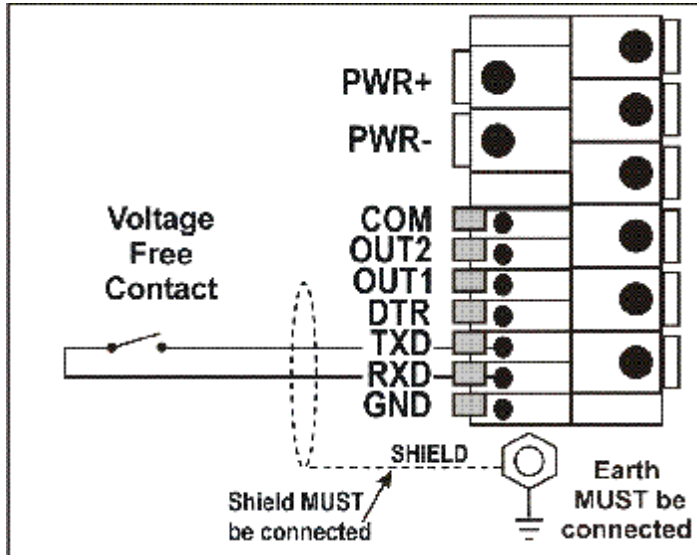

**WARNING**

The remote input is a voltage free contact (eg. button, mechanical relay). Connection of any active circuitry may damage the instrument.

### 6.4.5. Outputs

- Output drivers for the instrument are isolated open emitter transistor drives that are capable of driving up to a total of 300mA.
- This configuration allows for the direct connection of the instrument outputs to most types of PLC.
- The voltage applied to the COM terminal appears on the output lines (ie. OUT1 and OUT2) when the outputs are active (eg. to connect to a PLC connect +24V to the common terminal). The outputs can then be connected directly to PLC inputs so when the outputs are active the PLC will see a 24V signal.
- To drive external loads (eg. relays), connect the relay coil positive supply to the output common and the output line directly to one side of the relay coil.
- Connect the other end of the relay coil to the negative supply. It is recommended that fly-back diodes or transient suppressors be fitted across relay coils to limit switching noise.

### Outputs to Drive Relay

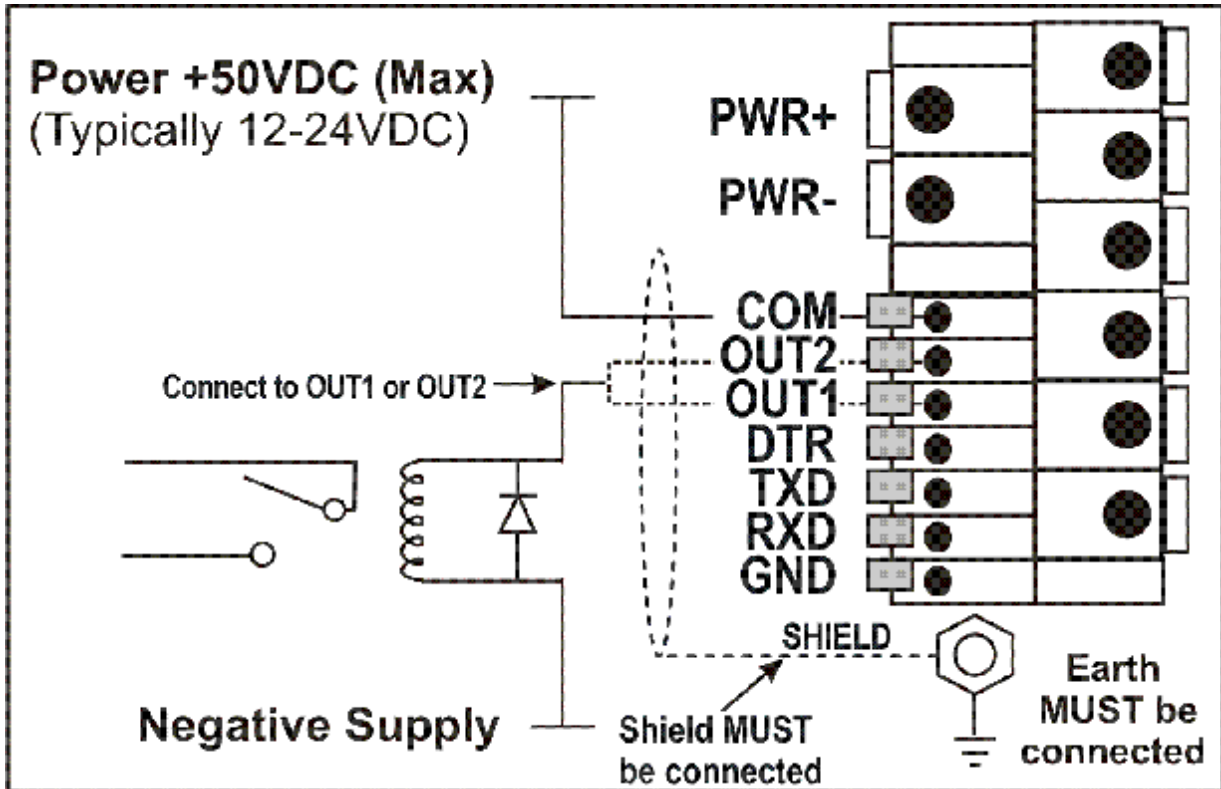

### Outputs to Drive PLC

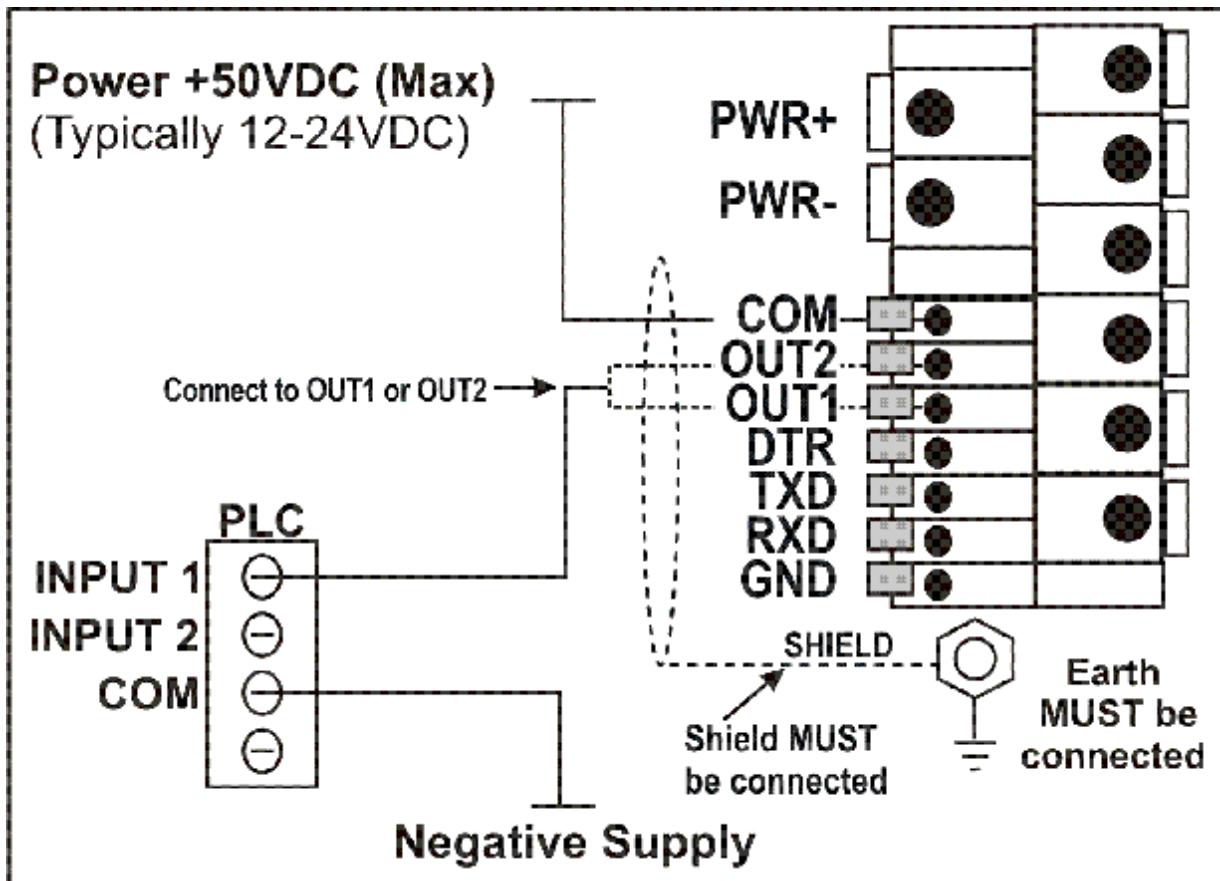

## 6.5. Connecting Shields

**To obtain full EMC or for RFI immunity, cable shields MUST be connected to the earth lug on the rear of the instrument.**

This figure shows the connecting cables restrained using cable ties fastened around the cable strain relief anchors.

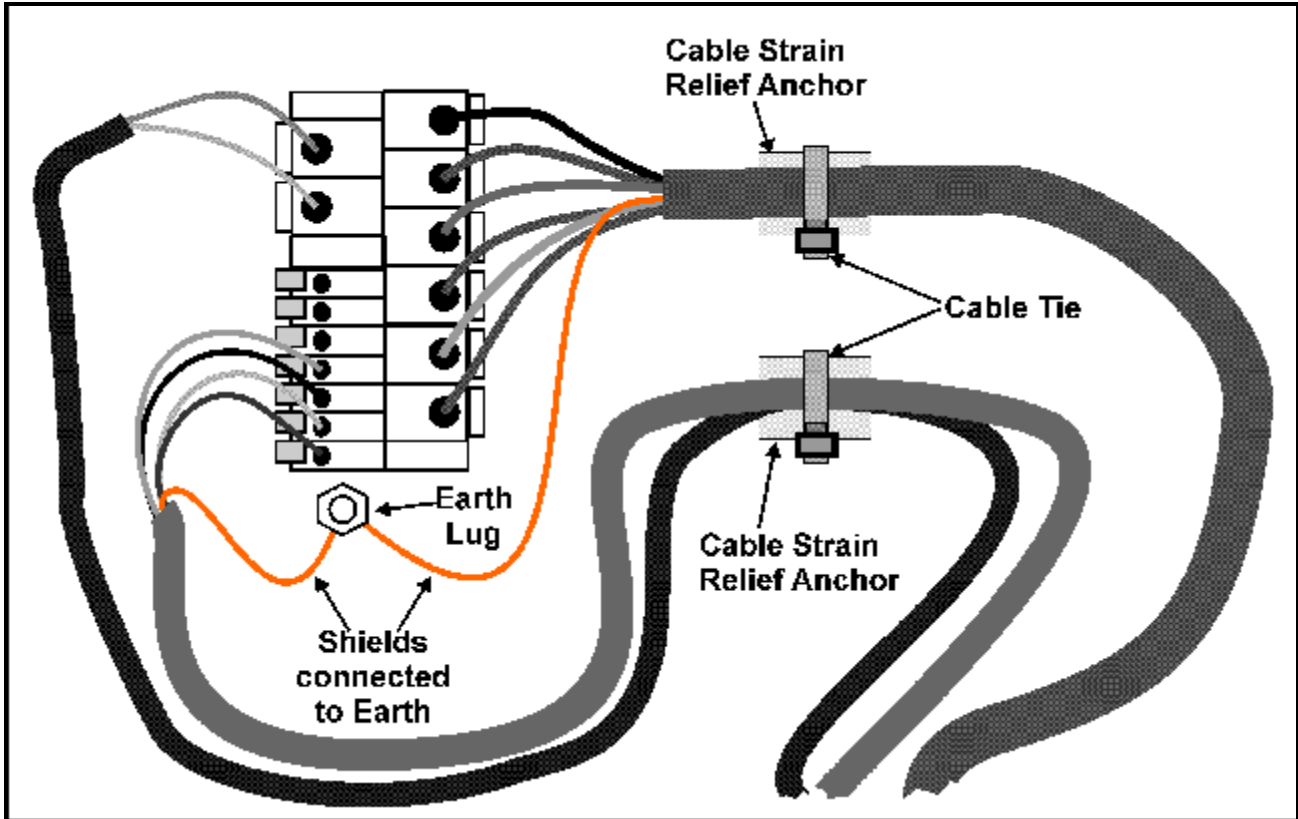

### 6.5.1. Cable Shield Connection and Earthing

- Care should be taken when connecting shields to maximise EMC or RFI immunity and minimise earth loops and cross-talk (interference) between instruments.
- For full EMC or for RFI immunity, termination of the cable shields at the earth lug is very important. The earth lug of the instrument must be separately connected to ground potential via a reliable link.
- The instrument should only be connected to earth via a single reliable link to avoid earth loops.
- Where each instrument is separately earthed, interconnecting cable shields should be connected at one end only.
- **Caution:** Some load cells connect the cable shield directly to the load cell (and therefore the scale base). Connection of the load cell cable shield in this situation may be site specific.

## 6.6. Regulatory Sealing Requirements

To comply with regulatory sealing requirements for each instrument, (ie. to ensure instruments are not accidentally or deliberately tampered with), it is important that proper sealing procedures be adhered to.

### 6.6.1. Sealing

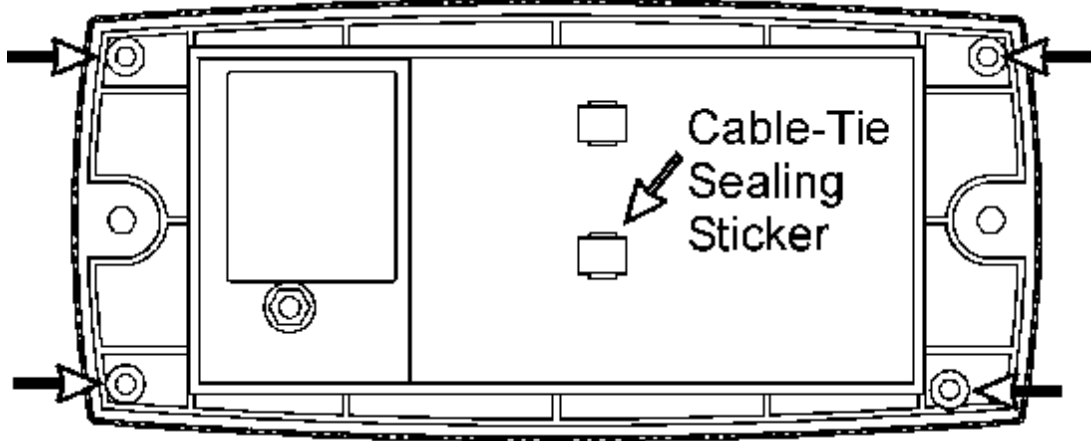

Affix sealing stickers to the rear of the instrument, over one or more screws in the locations indicated.

Also affix a sealing sticker over the load cell cable where the cable-tie strain relief is attached, as indicated.

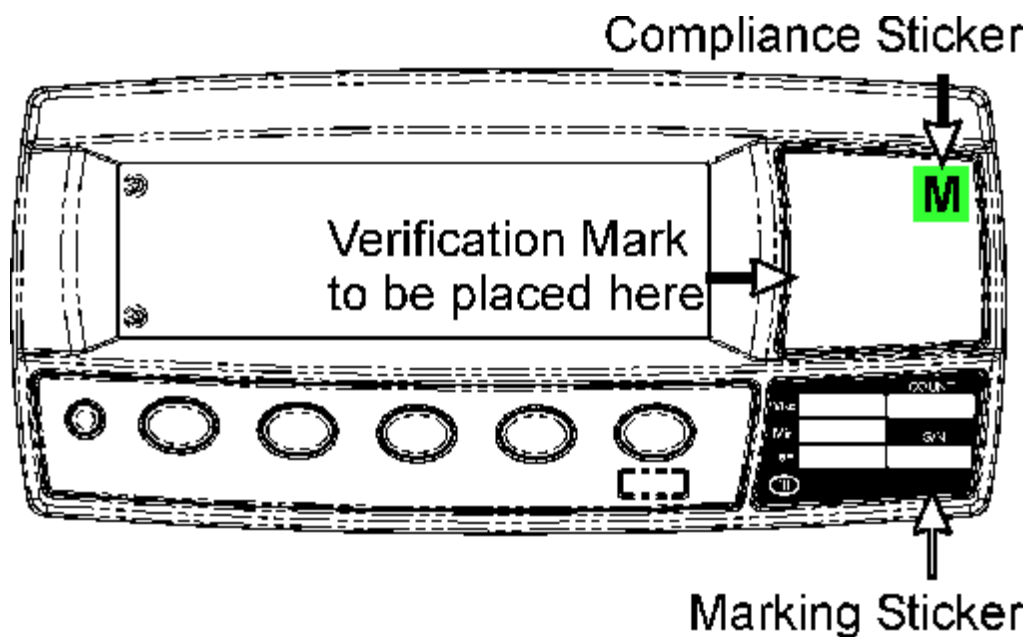

Affix stickers in the locations indicated.

## 7. Instrument Setup

### 7.1. Calibration Counter

The built-in calibration counter(s) monitor the number of times trade critical settings are altered. Refer to Trade Critical Settings below for more information and to the **OPTION:USE** setting page 17.

The table below describes when the counter(s) will increment.

<p><b>Industrial or OIML:</b> The <b>Calibration Counter</b> increments when trade critical settings are changed. An example of the counter is <b>C.00019</b>.</p>
--

<p><b>NTEP:</b> Two counters display.</p>
---

<p>The <b>Calibration Counter</b> increments when trade critical settings in the Calibration (<b>CAL</b>) menu are changed. An example of the counter is <b>C.00010</b>.</p>
--

<p>The <b>Configuration Counter</b> increments when other trade critical settings (ie. <b>not</b> in the <b>CAL</b> menu) are changed. An example of the counter is <b>F.00009</b>.</p>
---

#### 7.1.1. Trade Critical Settings

Trade critical settings can affect calibration and/or legal for trade performance. In this document the Å symbol indicates the setting is trade critical. Each time a trade critical setting is altered, the calibration counter will be incremented by one.

### 7.2. opto-LINK

For information on setting up using the opto-LINK cable refer to opto-LINK page 6.

### 7.3. Access Full Setup

**Full Setup** provides access to configure and calibrate the instrument. All items in all menus will be enabled in Full Setup.

**WARNING: Care should be taken to avoid inadvertently altering the Build or Calibration settings.**

- Ensure the instrument is on.
- Press and hold the **<POWER>** and **<FUNCTION>** keys together for two seconds.

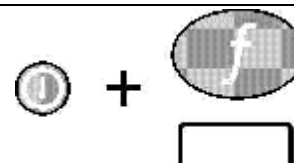

### 7.4. Access Safe Setup

**Safe Setup** restricts access to the trade critical settings (marked with  $\ddot{A}$ ).

- Ensure the instrument is on.
- Press and hold the **<POWER>** and **<ZERO>** keys together for two seconds.

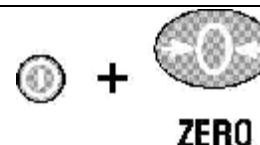

### 7.5. Exit Full or Safe Setup

To save settings, exit setup and return to the normal weighing mode use one of the following methods:







- **Method 1:** Press **<POWER>** and **<FUNCTION>** keys together for two seconds.
- **Method 2:** Press **<POWER>** and **<ZERO>** together for two seconds.
- **Method 3:** Select **- End -** from the menus.

**Warning:** If the power is interrupted while in setup (ie. by disconnecting the power cable or pressing the **<POWER>** key), unsaved settings will be lost.







### 7.6. Settings

The following tables identify the settings available for the instrument.







## Quick Start Manual Rev 2.2

GROUP (GRP)  ZERO	ITEM (ITM)  TARE	SELECT (SEL)  GROSS/NET	EDIT (EDT)  PRINT  Underline = Defaults	OK  
BUILD	DPÄ	Decimal Point Position	<u>000000</u> , 00000.0, 0000.00, 000.000, 00.0000, 0.00000	Accept
	CAPÄ	Maximum Capacity	000100 to 999999 Default = <u>003000</u> <SEL> changes position, <EDT> changes digit.	Accept
	RESÄ	Resolution (Count-By)	<u>1</u> , 2, 5, 10, 20, 50, 100	Accept
	UNITSÄ	Weighed Units	none, g, <u>kg</u> , lb, t	Accept
	HI.RESÄ	Resolution x 10 Mode	<u>OFF</u> , ON	Accept
	CABLEÄ	4-Wire or 6-Wire	4, <u>6</u>	Accept
OPTION	USEÄ	Scale Use	<u>INDUST</u> , OIML, NTEP	Accept
	FILTER	Reading Average (time in seconds)	none, 0.2, <u>0.5</u> , 1.0, 2.0, 3.0, 4.0	Accept
	MOTIONÄ	Motion Detection	OFF, <u>0.5-1.0</u> , 1.0-1.0 Default = 0.5 Graduations per Second	Accept
	INIT.Z	Initial Zero on Startup	<u>OFF</u> , ON	Accept
	Z.TRACÄ	Zero Tracking Sensitivity	<u>OFF</u> , SLOW (0.5 grads/sec), FAST (10 grads/sec)	Accept
	Z.RANGEÄ	Zero Operating Range	<u>-2_2</u> , -1_3, -20_20 Default = -2_2 (-2% to +2%)	Accept
	Z.BANDÄ	Zero 'Dead' Band	<SEL> changes position, <EDT> changes digit. Default = <u>0</u>	Accept







## Quick Start Manual Rev 2.2

	R.ENTRYÄ	Enable Rear Pushbutton for Full Setup Entry	<u>OFF</u> , ON	Accept
<b>GROUP (GRP)</b>  <b>ZERO</b>	<b>ITEM (ITM)</b>  <b>TARE</b>	<b>SELECT (SEL)</b>  <b>GROSS/NET</b>	<b>EDIT (EDT)</b>  <b>PRINT</b>	<b>OK</b>  
			Underline = Defaults	
CAL	ZEROÄ	<b>Zero Calibration Routine</b> Set between zero and full scale (Current weight displays)	<SEL> key to start. Current weight displays. Remove all weight. <SEL>, <EDT> or <OK> starts routine (Z.in P displays). <ITM> key to exit, <SEL>, <EDT> or <OK> to repeat routine.	
	SPANÄ	<b>Span Calibration Routine</b> Set between zero and full scale (Current weight displays)	<SEL> key to start <EDT> key to select clear linearisation points ( CLr.L y displays). or not ( CLr.L n displays). <OK> key to select alternative. Current weight displays. Add test weight. <SEL> or <OK> to show calibration weight value. Set correct weight. <SEL> changes position, <EDT> changes digit. <ITM> or <OK> starts routine (S.in P displays). <ITM> key to exit, <SEL>, <EDT> or <OK> to re-edit calibration weight and repeat routine.	







## Quick Start Manual Rev 2.2

GROUP (GRP)  ZERO	ITEM (ITM)  TARE	SELECT (SEL)  GROSS/NET	EDIT (EDT)  PRINT	OK  
			Underline = Defaults	
CAL (ctd)	ED.LINÄ	<p><b>Edit Linearisation Points</b> Set between zero and full scale</p> <p>L1. - - - Select Linearisation point 1 to 10 (L1, L2, L3, L4, L5, L6, L7, L8, L9, L10). (Approx. % of full scale)</p>	<p>&lt;SEL&gt; to step through list of points. &lt;OK&gt; to change selected point or &lt;ITM&gt; to exit. After &lt;OK&gt; current weight displays. Add test weight. &lt;OK&gt; to enter corrected weight. &lt;SEL&gt; changes position, &lt;EDT&gt; changes digit. &lt;OK&gt; starts routine (L.in P displays). &lt;ITM&gt; key to exit, &lt;OK&gt; to repeat routine.</p>	
	CLR.LINÄ	<p><b>Clear Linearisation Points</b></p> <p>L1. - - - Select Linearisation point 1 to 10 (L1, L2, L3, L4, L5, L6, L7, L8, L9, L10)</p>	<p>&lt;SEL&gt; to step through list of points. &lt;OK&gt; to select point to clear or &lt;ITM&gt; to exit. After &lt;OK&gt; press &lt;ITM&gt; to choose Cont. Y (Yes) or Cont. N (No). &lt;ITM&gt; to return to CLR.LIN.</p>	
	DIR.ZERÄ	<p><b>Direct Zero Calibration</b> (Current weight displays)</p>	<p>&lt;OK&gt; key to start. Current weight displays. &lt;OK&gt; to enter direct zero setting (in mV/V). &lt;SEL&gt; changes position, &lt;EDT&gt; changes digit. &lt;OK&gt; key to store new zero calibration. &lt;ITM&gt; to exit or &lt;OK&gt; to repeat operation.</p>	







## Quick Start Manual Rev 2.2

GROUP (GRP)  ZERO	ITEM (ITM)  TARE	SELECT (SEL)  GROSS/NET	EDIT (EDT)  PRINT	OK  
			Underline = Defaults	
CAL (ctd)	DIR.SPNÄ	Direct Span Calibration (Current weight displays)	<OK> key to start. Current weight displays. <OK> to enter direct span setting (in mV/V). <SEL> changes position, <EDT> changes digit. <OK> key to store new span calibration. <ITM> to exit or <OK> to repeat operation.	
	FAC.CALÄ	Factory Calibration Cont. N (No) Cont. Y (Yes)	<u>Cont. N</u> Warning: Choosing Cont. Y will restore default factory calibration in BUILD and CAL menus.	Accept
SPEC	SAFE.PC	Safe Setup Passcode	<u>(000000)</u> no passcode). Set up to 6 digit passcode. <SEL> changes position, <EDT> changes digit. Activated only when FULL.PC is also set.	Accept
	FULL.PC	Full Setup Passcode	<u>(000000)</u> no passcode). Set up to 6 digit passcode. <SEL> changes position, <EDT> changes digit.	Accept
	KEY.LOC	Front Panel Key Locking P12345 (P for Power key. Other keys numbered from the left, ie. Zero=1.)	<u>P12345</u> Character indicates key is unlocked. (-) Dash indicates key is locked. <SEL> changes position, <EDT> changes digit.	Accept
	KEY.FN	<FUNCTION> Key Setting	<u>NONE</u> , TEST, COUNT, UNITS, HOLD, PEAK.H, LIVE.WT, SHOW.T, HI.RES, A.TARE, SET.PT	Accept





## Quick Start Manual Rev 2.2

GROUP (GRP)  ZERO	ITEM (ITM)  TARE	SELECT (SEL)  GROSS/NET	EDIT (EDT)  PRINT	OK  
SPEC (ctd)	AUT.OFF	Auto Power Off / Battery Operation	<u>NEVER</u> , 1, 5, 10 (time in minutes) Default = Never powers off automatically (Battery: powers down after 30 minutes)	Accept
	B.LIGHT	Backlight Operation	<u>ON</u> , OFF (Automatically turns indicator off after 10 seconds of inactivity)	Accept
	REM.FN	Remote Function	<u>NONE</u> , KEY1 to KEY5, BLANK (Activated only when SERIAL:TYPE is set to KEY)	Accept
SERIAL	TYPE	Serial Output Type	<u>NET</u> , AUTO, SINGLE, PRINT, AUTO.PR	Accept
	FORMAT	Serial Output Format	<u>MASTER</u> , CUSTOM, FMT_1, FMT_2,	Accept
	BAUD	Serial Baud Rate	2400, 4800, <u>9600</u>	Accept
	BITS	Serial Format Options Position 1: Parity Position 2: Data Bits Position 3: Stop Bits Position 4: DTR Handshake	<u>N 8 1</u> - (Default Serial Format Options) <SEL> changes position, <EDT> changes digit. Parity: N None, O Odd, E Even Data Bits: 7 or 8 data bits Stop Bits: 1 or 2 stop bits DTR: (-) DTR disabled or d DTR enabled	Accept
	ADDRES	Instrument Address	01 to <u>31</u> <SEL> changes position, <EDT> changes digit.	Accept





## Quick Start Manual Rev 2.2

GROUP (GRP)  ZERO	ITEM (ITM)  TARE	SELECT (SEL)  GROSS/NET	EDIT (EDT)  PRINT	OK  
SERIAL (ctd)	RST.CONÄ	Reset Printed Consecutive Numbers to 1 Cont. N (No) Cont. Y (Yes)	<u>Cont. N</u> <ITM> to choose Cont. Y (Yes) or Cont. N (No)	Accept
SET.PTS	SETPT.1	Control Type Setpoint 1 (Output 1)	<u>OFF</u> , ON, OVER, UNDER, MOTION, ZERO, NET, ERROR (Displayed)	Accept
	SRC.1	Weight Source	<u>GROSS</u> , DISP, NET (Displayed)	Accept
	TARG.1	Target for Over and Under Weight Setpoint 1 (Output 1)	-99999 to 999999 Default = <u>000000</u>	Accept
	SETPT.2	Control Type Setpoint 2 (Output 2)	<u>OFF</u> , ON, OVER, UNDER, MOTION, ZERO, NET, ERROR (Displayed)	Accept
	SRC.2	Weight Source	<u>GROSS</u> , DISP, NET (Displayed)	Accept
	TARG.2	Target for Over and Under Weight Setpoint 2 (Output 2)	-99999 to 999999 Default = <u>000000</u>	Accept

## Quick Start Manual Rev 2.2

GROUP (GRP)  ZERO	ITEM (ITM)  TARE	SELECT (SEL)  GROSS/NET	EDIT (EDT)  PRINT	OK  <input type="text"/>
			Underline = Defaults	
CLOC	FORMAT	Date Format Setting	<u>dd.mm.yy</u> or mm.dd.yy	Accept
	YEAR	Year Setting	2000 to 2099 <SEL> changes position, <EDT> changes digit.	Accept
	MONTH	Month Setting	01 to 12 <SEL> changes position, <EDT> changes digit.	Accept
	DAY	Day Setting	01 to 31 <SEL> changes position, <EDT> changes digit.	Accept
	HOUR	Hour Setting	00 to 23 <SEL> changes position, <EDT> changes digit.	Accept
	MINUTE	Minute Setting	00 to 59 <SEL> changes position, <EDT> changes digit.	Accept
TEST	SCALE	Scale Base Test Display	Display reads in milliVolts-per-Volt (factory calibrated to 0.1%) Verify the correct load cell capacity and/or load cell wiring is used. Remove weight from scale.	
	FRC.OUT	Force Outputs	<EDT> advances through outputs (ie. ON.1 and ON.2) <OK> turns outputs off and exits test. Default = <b>OFF</b>	
	O.LOAD	Input Overload Count	Displays the number of occurrences of an input overload.	Return

## Quick Start Manual Rev 2.2

GROUP (GRP)  ZERO	ITEM (ITM)  TARE	SELECT (SEL)  GROSS/NET	EDIT (EDT)  PRINT  Underline = Defaults	OK  <input type="text"/>
TEST (ctd)	CLR.OLD	Clear Overload Count Cont. N (No) Cont. Y (Yes)	<u>Cont. N</u> Choosing Cont. Y will clear the overload count.	Accept
FACTRY	DEFLT	Restore Factory Defaults Cont. N (No) Cont. Y (Yes)	<u>Cont. N</u> Warning: Choosing Cont. Y will clear all stored data except BUILD and CAL menus.	Accept
- END -	EXIT SETUP	Save settings and return to normal weighing mode		Accept

## 8. Error Messages

### 8.1. Weighing Errors

- Check Setup = This item can be checked on site by service personnel

Error	Description	Resolution
(U - - - -)	The weight is below the minimum allowable weight reading.	Increase the weight or decrease the minimum allowable weight reading.
(O - - - -)	The weight is above the maximum allowable weight reading. Warning - overloading may damage mechanical scale elements.	Check the condition of load cell connections. Check for damaged load cell.
(ZERO) (ERROR)	The weight reading is beyond the limit set for Zero operation. The operation of the <b>&lt;ZERO&gt;</b> key is limited in the setup during installation. The indicator cannot be Zeroed at this weight.	Increase the Zero Range (Z.RANGE) or use the <b>&lt;TARE&gt;</b> key instead.
(STABLE) (ERROR)	Scale motion has prevented a <b>&lt;ZERO&gt;</b> , <b>&lt;TARE&gt;</b> or <b>&lt;PRINT&gt;</b> operation from occurring on command.	Try the operation again once the scale is stable.

## 8.2. Setup and Calibration Errors

<b>Error</b>	<b>Description</b>	<b>Resolution</b>
(ENTRY) (DENIED)	The instrument may be in Safe Setup and an item that needs Full Setup has been selected for editing.	Access Full Setup to edit the item.
	When accessing setup, more than three attempts have been made with the incorrect passcode.	Turn the instrument off. When the instrument is turned back on, enter the correct passcode to access setup.
(LIN.PT) (LO)	An attempt has been made to place a linearisation point below zero.	Incorrect linearisation point entered (must be between zero and full scale).
(PT.TOO) (CLOSE)	An attempt has been made to place a calibration point too close to an existing calibration point.	Re-enter the calibration point. Points must be spaced by at least 2% of full scale from each other.
(RES) (LO)	The scale build is configured for less than 100 graduations.	Check the resolution (count-by) and capacity settings.
(RES) (HIGH)	The scale build is configured for more than 30,000 graduations.	Check the resolution (count-by) and capacity settings.
(SPAN) (LO)	The load cell signal range (span) is too small for these settings.	Incorrect span weight entered (must be between zero and full scale). Scale wiring incorrect. Wrong load cell capacity (too large). Wrong or no calibration weight added to scale.
(SPAN) (HI)	The load cell signal range (span) is too large for these settings.	Incorrect span weight entered (must be between zero and full scale). Scale wiring incorrect. Load cell capacity too small for application.

<b>Error</b>	<b>Description</b>	<b>Resolution</b>
(ZERO) (LO)	An attempt has been made to calibrate zero below -2mV/V.	Scale wiring incorrect.
(ZERO) (HI)	An attempt has been made to calibrate zero above +2mV/V.	Remove all weight from scale. Scale wiring incorrect.

### 8.3. Diagnostic Errors

- Check: This item can be checked on site by service personnel.
- Return for Service: The instrument must be returned to the manufacturer for factory service.

Error	Description	Resolution
(E0001)	The power supply voltage is too low.	Check supply
(E0002)	The power supply voltage is too high.	Check scale / cables
(E0010)	The temperature is outside of allowable limits.	Check location
(E0020)	Scale build is incorrect. The number of graduations has been set too low or too high.	Fix up scale build
(E0100)	The digital setup information has been lost.	Re-enter setup
(E0200)	The calibration information has been lost.	Re-calibrate
(E0300)	All setup information has been lost	Enter setup and calibrate
(E0400)	The factory information has been lost.	Return for Service
(E0800)	The EEPROM memory storage chip has failed	Return for Service
(E2000)	ADC Out of Range Error. This may be caused from a broken load cell cable.	Check BUILD:CABLE setting. Check load cell cable, wiring, etc.
(E4000)	The battery backed RAM data has lost data.	Re-enter setup
(E8000)	The FLASH program memory is incorrect	Return for Service

The **E** type error messages are additive. For example if instrument is running off batteries and the temperature drops, the battery voltage may be too low. The resulting error messages will be **E0011** (0001 + 0010). The numbers add in hexadecimal as follows:

**1 - 2 - 3 - 4 - 5 - 6 - 7 - 8 - 9 - A - B - C - D - E - F**  
 (For example, 2 + 4 = 6, or 4 + 8 = C)